

The piston pump is a hydraulically operated positive displacement pump that has been designed for pumping delicate and viscous fluids. A hydraulic cylinder moves a double effect piston. This piston divides the pump housing into two chambers. Each chamber has one inlet and one outlet connection. These connections allow entry and exit of large pieces which can be pumped without damage. An open separator chamber seals the product chamber from the oil system and prevents any contact between the hydraulic oil and the product.

The piston pump is very useful in food industry where pumping delicate foodstuffs is a problem. The unique design is very economic on spare parts and does not contaminate the product. Very high pressures can be achieved. The piston pump can be used in any industry where high pressure drops, high viscosity and maintaining product integrity is crucial.

### APPLICATIONS:

- High viscosity fluids.
- Shear sensitive fluids.
- (Aseptic) food applications.
- Fluids with large particles.
- Industrial applications.

### MATERIALS:

- Product wetted components.
- AISI 316L stainless steel.
- Non product wetted components.
- AISI 304 stainless steel.

### FINISHING:

- External surfaces polished.
- Internal surfaces (product wetted parts):
- roughness < 0,5 microns.

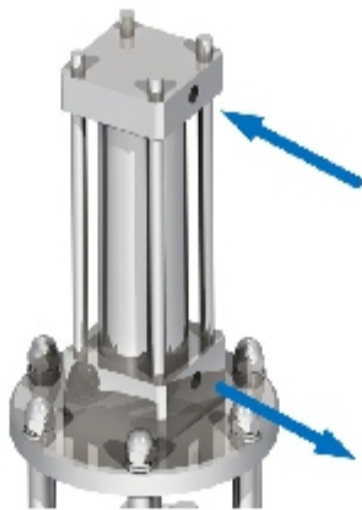

### The Main Features of our Piston Pump are:

- Hygienic design
- It can work up to 120°C (248°F)
- It can stand high working pressures (up to 30 bar)
- It is suitable for under vacuum processing
- It allows Cleaning In Place processes
- Low maintenance costs due to the reduced number of long-life spare parts
- There are no elastomers
- Adjustable pump flow
- It solves the sliding effect of viscous products.



### RANGE:

The use of clap valves allows to be pumped whole fruit, diced fruit and vegetables.



The pump is driven by hydraulic oil from the power pack that enters the hydraulic Cylinder from alternate directions. This way the piston is moved up and down. An alternative version with pneumatic cylinder can be supplied for low pressure applications (< 5 bar).